

Mapvision | Q

100% x 100% In-Line Inspection

Inspect 100% of the features for 100% of your production within TAKT time – even for the most complex structural components.

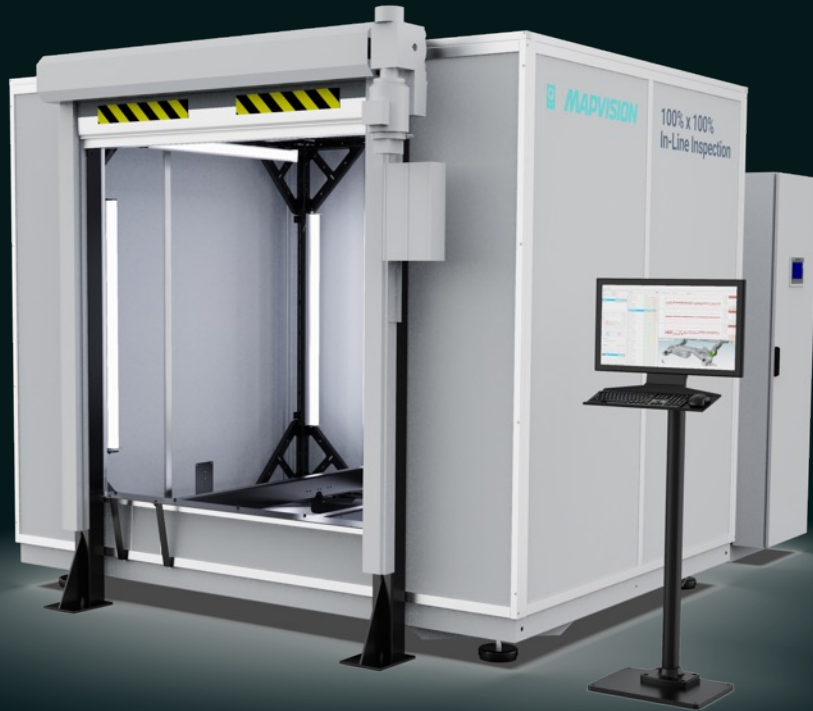
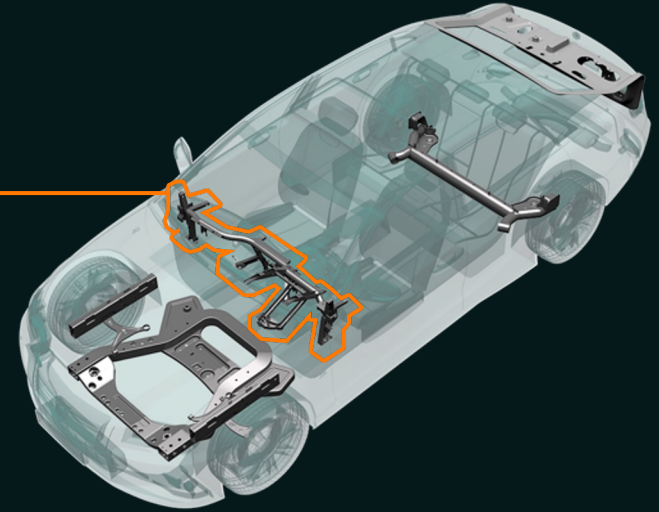

MAPVISION
SEE YOUR POTENTIAL

— About Mapvision

Your Eyes on the Factory Floor to **Manufacture Smarter**

We develop new generation in-line quality inspection technologies with deep know-how in machine vision and photogrammetry. Our patented solutions equip global manufacturers with preventive and proactive capabilities – helping them to exceed their efficiency goals in ways that have not been possible with conventional systems.



Technology

From research in photogrammetry and machine vision to large R&D projects in weld seam inspection and closed-loop manufacturing, we drive the technology forward to create solutions that shape the future of manufacturing.

Inspection Systems

Our robust and fully-digital in-line inspection systems that are built to withstand the factory conditions and equipped with our patented technologies enable our customers increase productivity, cut costs, and reach their efficiency goals.

Software and Analytics Tools

We provide software solutions to monitor, analyse, and report actionable production data from shop floor to top floor – across functions, people, and machines.

Lifecycle Services

From initial requirements discovery during line set up to project management, technical consulting, and support and maintenance services; we support our customers throughout their entire production lifecycle.

— Our Core Capability

100% x 100% In-Line Inspection

Mapvision Q enables manufacturers to inspect 100% of the features on 100% of their production within their TAKT time even for the most complex parts with hundreds of features – helping them to improve productivity, cut costs, and manufacture smarter.

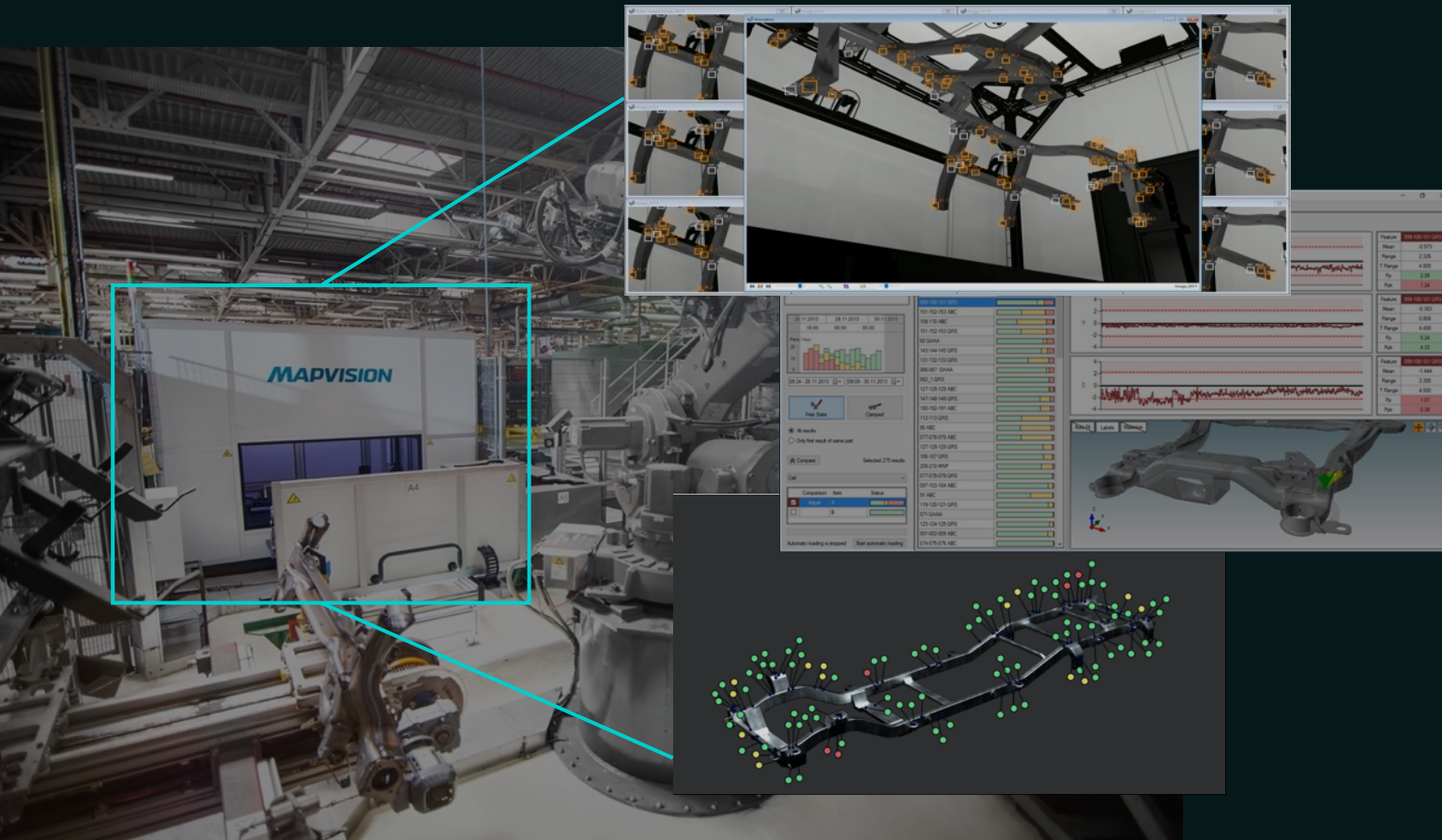

Optimize Productivity

Achieve 100% quality containment and deep-dive process control. With deep-dive data from each part and feature; catch all defective parts, get real-time feedback on process performance, and rapidly adjust production lines to reduce internal PPMs. Cut adjustment downtime and increase overall OEE with deeper and smarter, real-time analytics.

Cut Quality Costs

Cut the cost of poor quality and reduce the cost of good quality. Mitigate OEM line shutdowns due to defective parts, avoid expensive warranty claims, and eliminate manual sorting activities by inspecting all features on each part manufactured – even for the complex structural parts such as ladder frames.

Manufacture Smarter

Take advantage of digitalization and manufacturing big data. Achieve advanced part traceability and even retroactively inspect parts. Become more flexible by eliminating your dependence on CMMs with in-line absolute measurement. Conduct measurement program updates within minutes instead of hours with a 100% digital and software-driven in-line inspection solution.

— System Capabilities

Mapvision | Q

100% x 100% In-Line Inspection

▶ Safe Quality Containment

Detect out-of-spec parts as soon as they are produced to safely contain them within your facility. Avoid OEM line shutdowns and expensive warranty claims. Build a reputation for 100% delivery quality.

▶ Real-Time Process Data Analytics

Monitor your process performance for each feature, component, and production cell in real-time. Utilize deep-dive data to reveal complex variation patterns and trends. Prevent scrap and enable advanced closed-loop manufacturing processes.

▶ Advanced Traceability

Associate each part produced with its whole production history, inspection results, and raw inspection data for advanced part traceability and retroactive inspection. Eliminate OEM sorting, avoid batch recalls, and measure parts that are no more physically available in your premises.

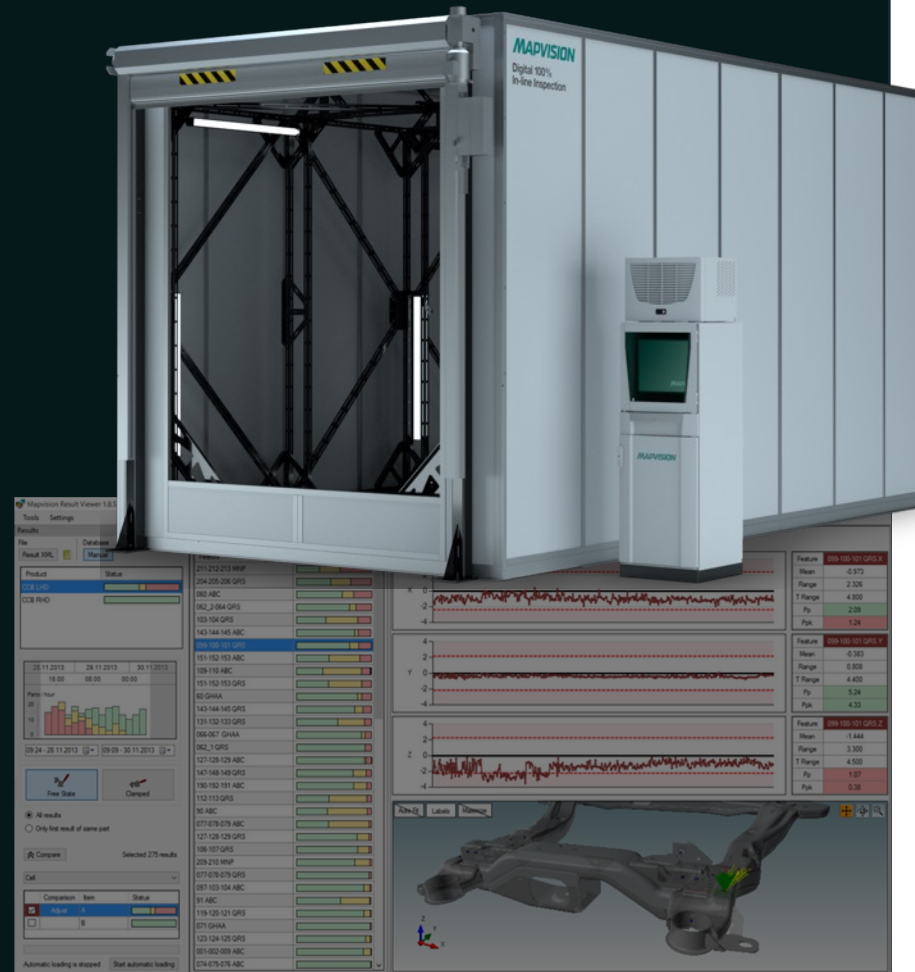

■ Inspect Hundreds of Features in 30 Seconds

Our proprietary multi-camera technology provides a new generation solution that can inspect hundreds of features in approximately 30 seconds by utilizing the most recent advancements in machine vision and photogrammetry.

■ Geometric Measurement and Presence Check

Mapvision Q conducts 3D geometric measurements and presence checks within the same inspection cycle – delivering you a comprehensive quality control solution with a single system.

■ Mapvision Absolute Measurement

Mapvision Q eliminates your dependence on CMMs, correlation studies, and reference parts to deploy and update in-line measurement programs. The system directly uses the CAD model of the part as measurement reference and delivers CMM level accuracy – serving as a reliable, stand-alone measurement solution.

■ Robustness and Reliability

The system's enclosed and isolated measurement chamber protects cameras from external light, dust, and vibration on the factory floor while temperature variations are mitigated by an integrated temperature compensation system. Mapvision's multi-camera based redundancy system ensures that even in case of an unlikely camera failure, the system can stay operational and deliver measurements without any compromise in accuracy.

— Capabilities You Gain

Improving Product Control and Process Capability for Automotive Tier1 Suppliers and OEMs

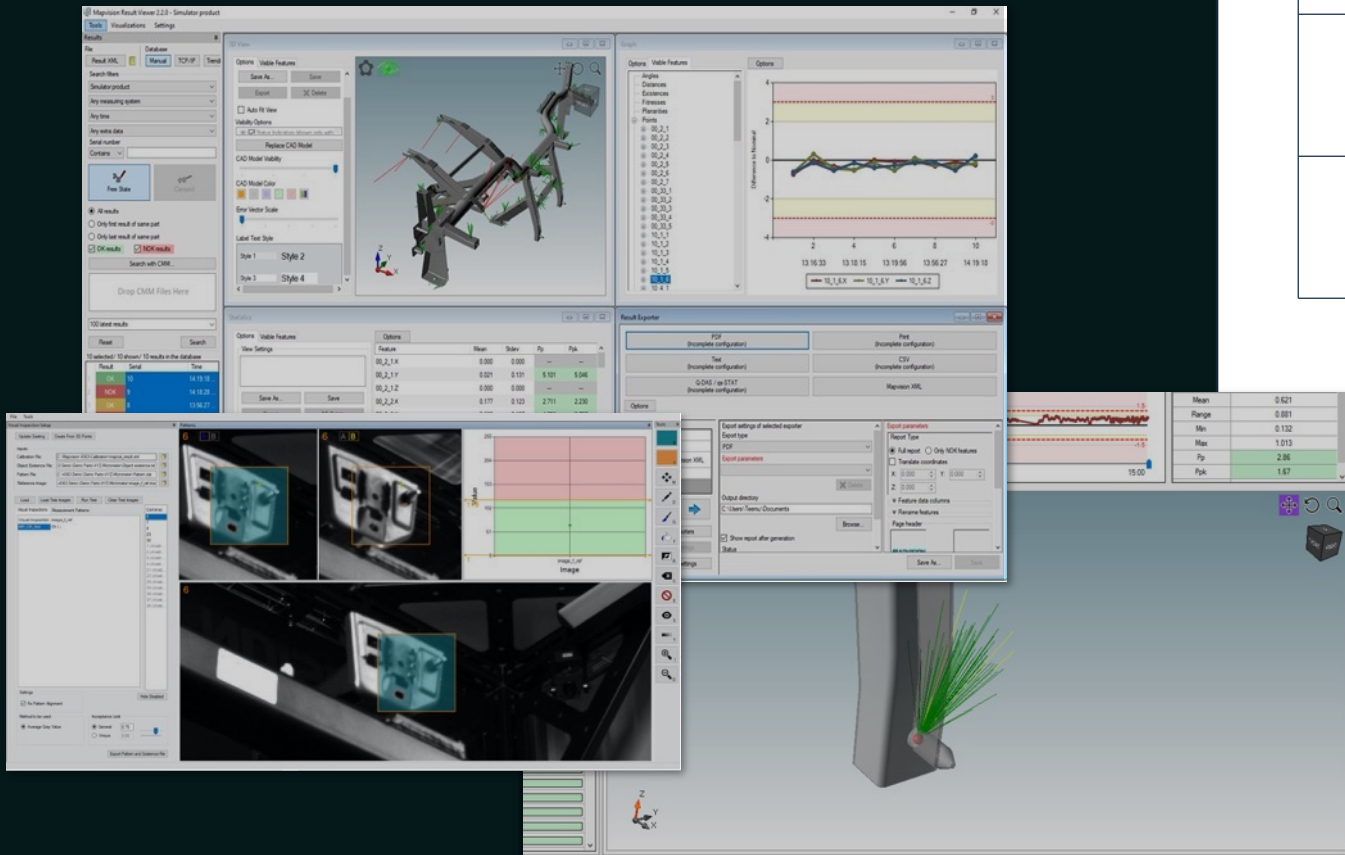

Mapvision | Q

100% x 100% In-Line Inspection

Product Analytics

Process Analytics

Early Defect Awareness and Visualization

Advanced Cell Monitoring and Predictive Maintenance

Advanced Part Traceability

Early Detection of Process Trends and Steps

Retroactive Inspection

Fast Process Adjustment and Fine-Tuning



100% Delivery Quality and Increased Productivity

— Technology

Mapvision Multi-Camera Technology



Unparalleled Robustness with Self Diagnosis and Camera Redundancy

Mapvision's patented multi-camera technology enables Mapvision Q to internally evaluate its own measurement process by comparing results from multiple triangulations.

Even in case of a camera obstruction, the system can detect and isolate the problem while continuing to provide uncompromised results from other triangulations – providing reliable, uninterrupted performance at all times.

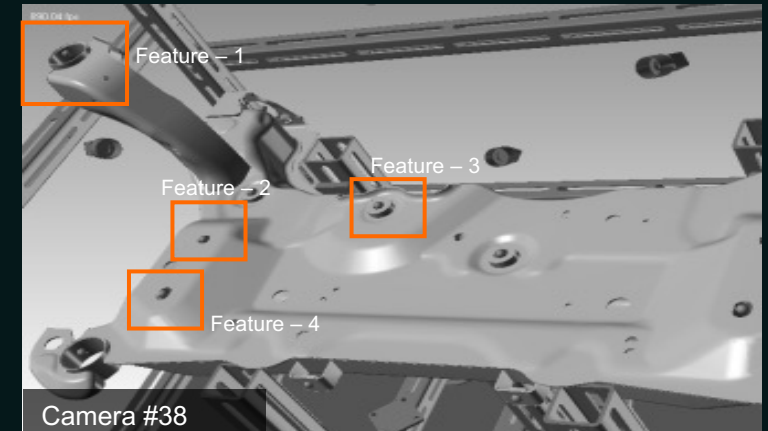
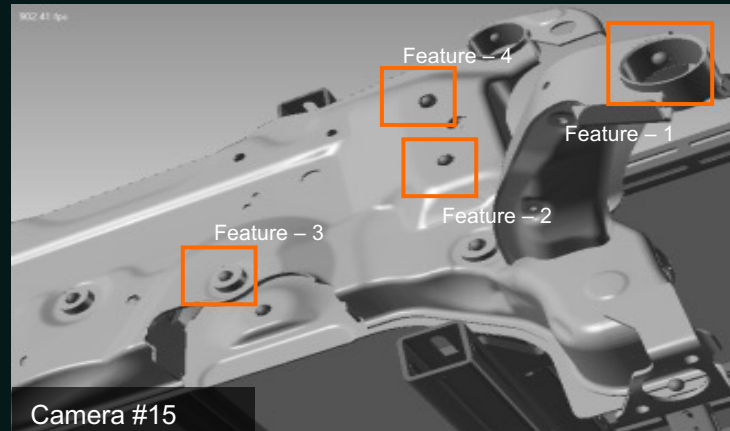
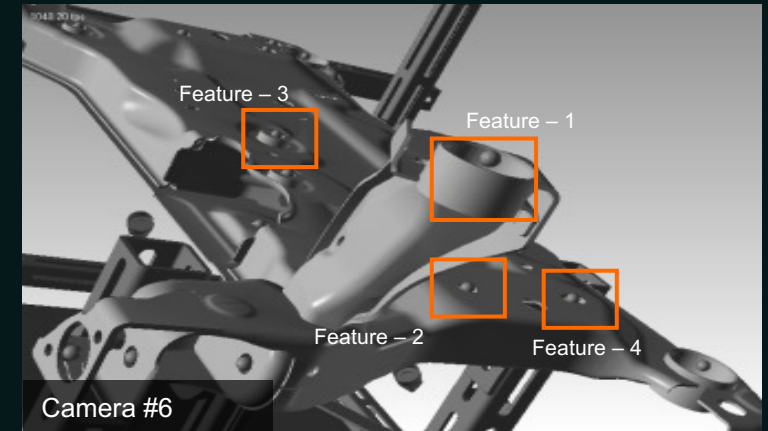
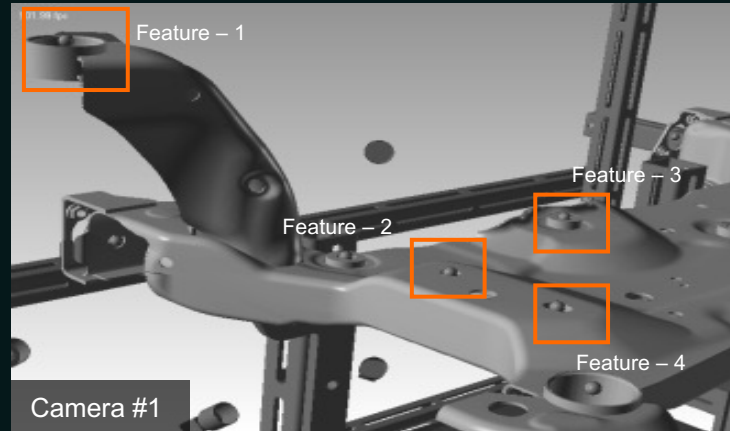

Image: Detecting multiple features from multiple angles with different cameras for multi-camera triangulation

Machine Vision

Observe the whole volume of the part with the multi-camera setup. Collect multiple images for each feature and identify the features with powerful machine vision algorithms.

Photogrammetry

Extract the 3D dimensions from 2D images for each feature identified with advanced photogrammetry algorithms.

Multi-Camera Triangulation

Aggregate measurement results from multiple combinations of cameras unlike conventional sensor systems using single-point triangulation and increase robustness.

Fully Image-Based Inspection Process **Enabling Complete Digitalization**

Retroactive Inspection

Users can go back to the database to inspect completely new features or to re-run inspections for modified specifications – even if the parts are not physically available any more in their premises.

Capture Images

An extensive set of fixed cameras capture images of the whole inspection volume and features from multiple angles within few seconds.



Via Hardware on Site

Save Images to Database

Images are saved to the image database of the measurement unit to be used by Mapvision's inspection algorithms.

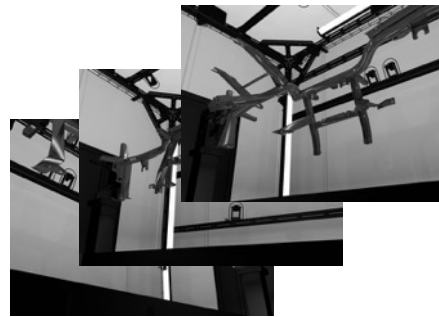

Completely via Software

Inspect on the Images

Mapvision's powerful machine vision and photogrammetry algorithms conduct geometric measurements and presence check directly on the collected images.



Analyze and Modify

Results are made available in real-time to conduct deep-dive analysis. Users can adjust the measurement program, add new inspection points, and even manage the whole process remotely at any point.

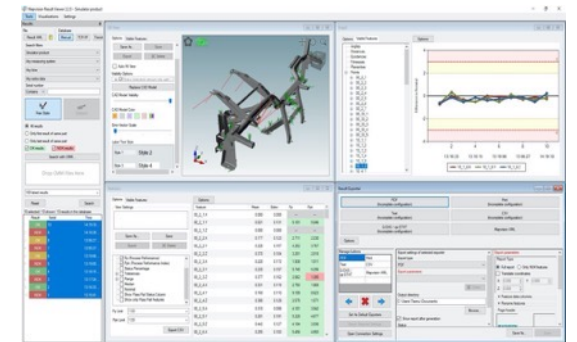

Approx. 30 seconds inspection cycle per part

— Inspected Parts

Inspect Parts of **All Sizes** and **High Complexity**

Inspect a wide range of welded, cast, and stamped components to ensure a stable output quality – no matter how large or complex your part is. From side beams and axle components to front end modules, underbody modules, entire ladder frames, and EV battery packs; Mapvision helps you increase productivity and quality.

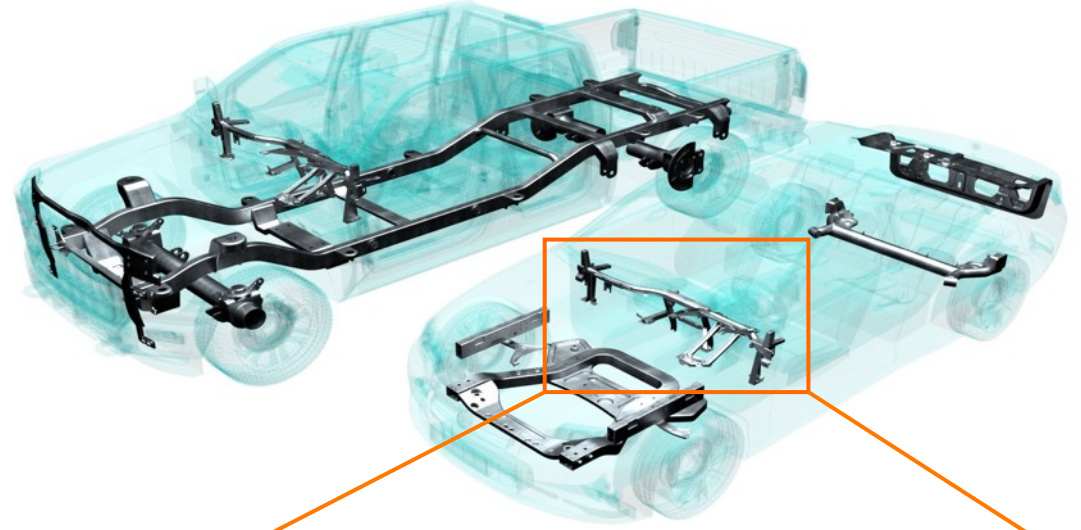
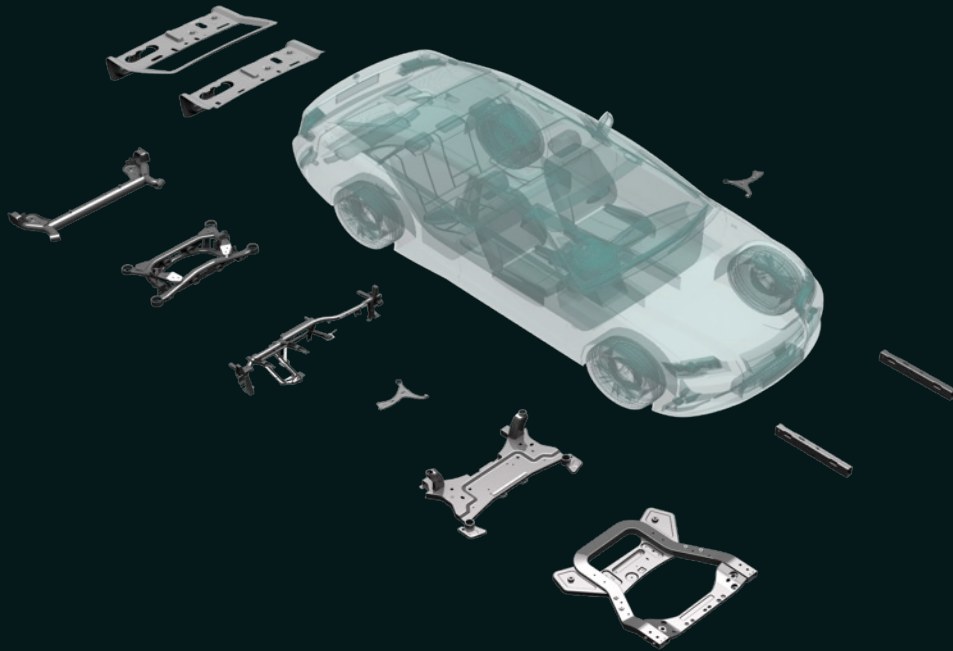

— Inspected Feature Types

Some of The Common Feature Types You can Inspect

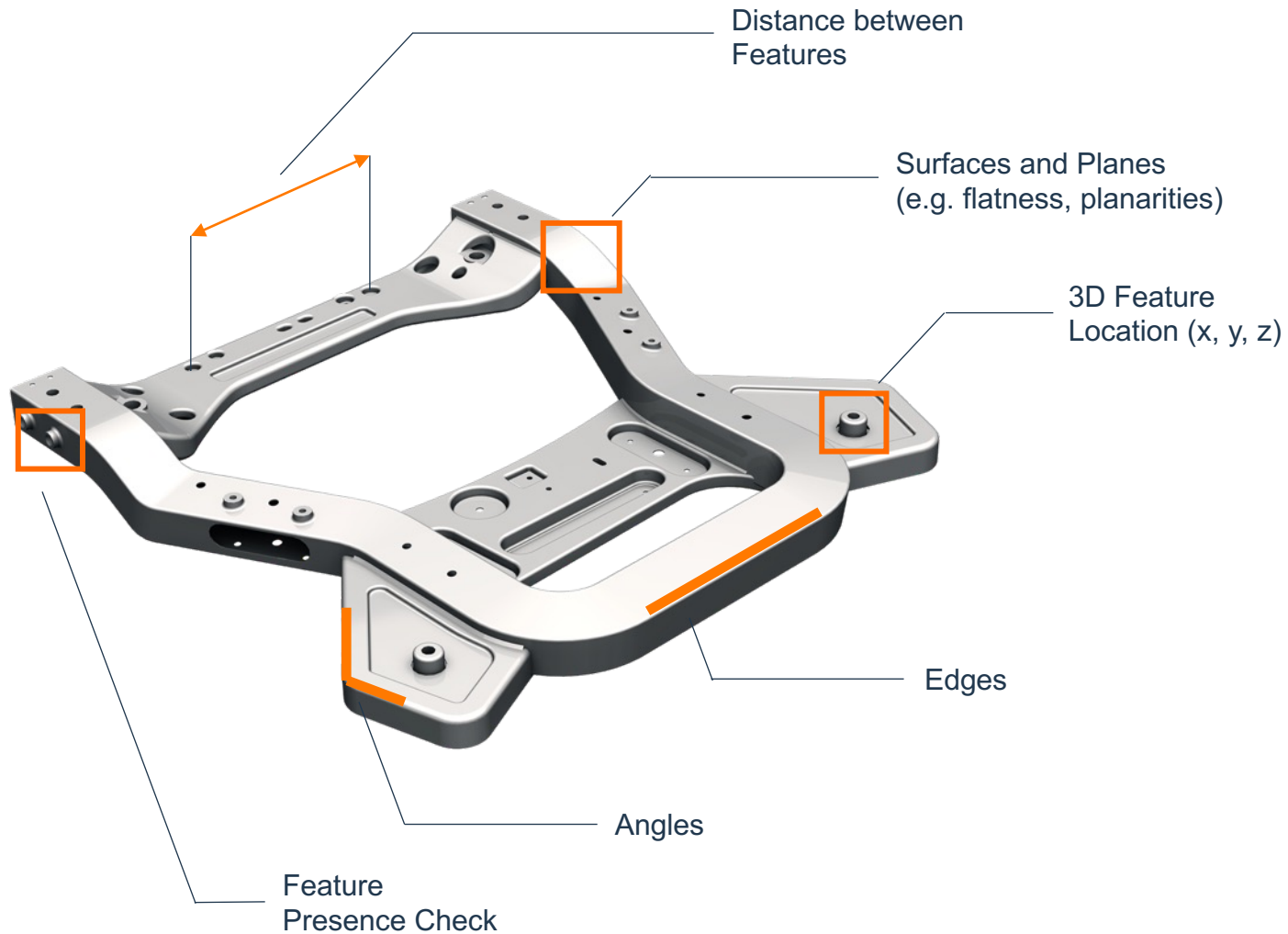

Surface and Edge Analysis with Light Projection

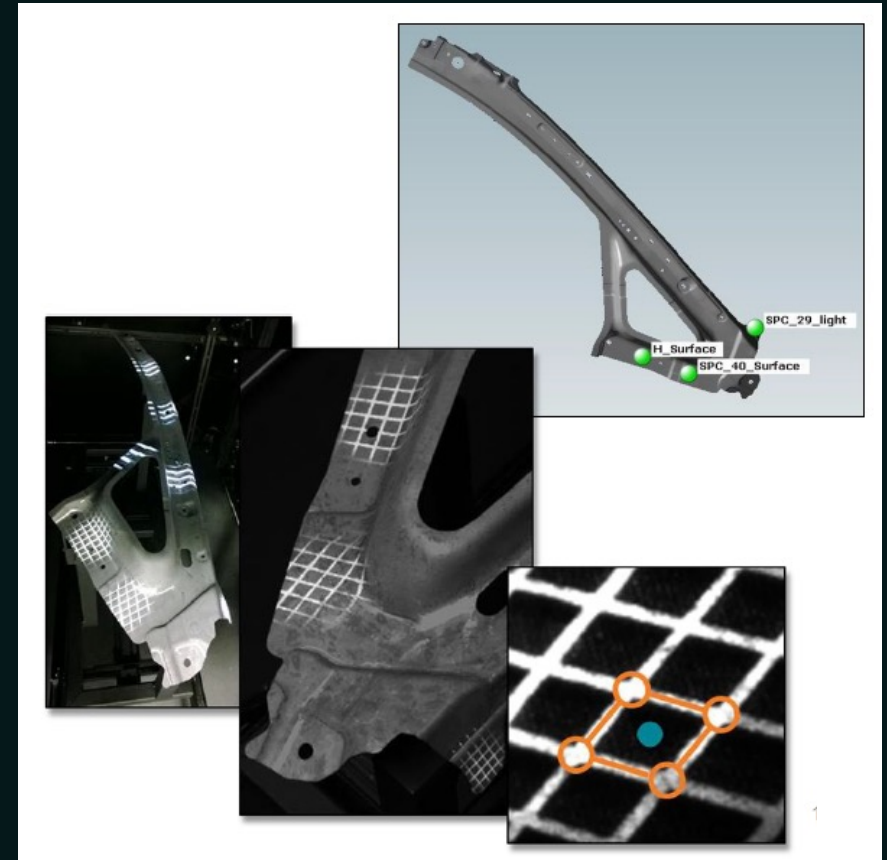

— Global Footprint

A Technology Recognized Worldwide by Global Automotive Manufacturers

200+

Systems Operational
Worldwide

600+

Parts and Variants Being
Inspected by Mapvision
Systems

88%

of Customers Already Have
Made Repeat Purchases



Mapvision HQ
Helsinki, Finland

Mapvision GmbH
Munich, Germany

Mapvision Inc.
Ohio, US

Mapvision Ltd.
Shanghai, China

Contact Us

www.mapvision.fi

MAPVISION
SEE YOUR POTENTIAL



Mapvision HQ

Helsinki, Finland

Mapvision Ltd.

Malminkartanonkuja 4
FI-00390 Helsinki, Finland

Mapvision Americas

Ohio, United States

Mapvision Inc.

5601 Creek Road, Suite C
Cincinnati, OH 45242, USA

Mapvision EMEA

Munich, Germany

Mapvision GmbH

Oskar-von-Miller-Ring 20
DE-80333 Munich, Germany

Mapvision China

Shanghai, China

Mapvision Ltd.

麦普威有限公司
34th Floor, BLDG.A, 391 Guiping
Road, Xuhui District, Shanghai